



On-the-Job Training

Mechanical Maintenance
Reverse Indicator Alignment

Mentor Guide



Equatorial Guinea LNG Holding Limited

Courseware Release Version 1.8

© 2009 EGLNG

Notice of Rights

No part of this publication may be reproduced, transmitted, transcribed, stored in a retrieval system, or translated into any language or computer language, in any form or by any means, electronic, mechanical, magnetic, optical, chemical, manual, or otherwise, without the prior written permission of EG LNG Holding Limited except under the terms of a courseware site license agreement.

Trademark Notice

Throughout this courseware title, trademark names are used. Rather than just put a trademark symbol in each occurrence of a trademarked name, we state we are using the names only in an editorial fashion and to the benefit of the trademark owner with no intention of infringement of the trademark.

Notice of Liability

The information in this courseware title is distributed on an 'as is' basis, without warranty. While every precaution has been taken in the preparation of this course, neither the authors shall have any liability to any person or entity with respect to any loss or damage caused or alleged to be caused directly or indirectly by the instruction contained in this book.

Disclaimer

We make a sincere effort to ensure the accuracy of the material described herein; however, the authors makes no warranty, expressed or implied, with respect to the quality, correctness, reliability, accuracy, or freedom from error of this document or the products it describes. Data used in examples and sample data files are intended to be fictional. Any resemblance to real persons or companies is entirely coincidental.

Terms and Conditions

Sample versions: If the version of courseware that you are viewing is marked as NOT FOR TRAINING, SAMPLE, or similar, then it is made available for content and style review only and cannot be used in any part of a training course. Sample versions may be shared but cannot be re-sold to a third party.

For licensed users: This document may only be used under the terms of the license agreement from EG LNG, reserves the right to alter the licensing conditions at any time, without prior notice.

Reverse Dial Indicator Alignment

Table of Contents

Competency 3.5	4
<i>Terminal Objective</i>	4
<i>Enabling Objectives</i>	4
Practice Exercise	5
PE 3.5.1 - Measure and correct any soft foot	5
PE 3.5.2 - Measure and plot pre-alignment dimensions	7
PE 3.5.3 - Measure and record dial indicator sweep readings.....	9
PE 3.5.4 - Calculate and plot vertical offset	11
PE 3.5.5 - Calculate and plot horizontal offset.....	13
PE 3.5.6 - Correct coupling misalignment.....	15
PE 3.5.7 - Determine motor magnetic center.....	17
PE 3.5.8 - Measure and record final dial indicator readings.....	19
Performance Test	21
PT 3.5.1 - Measure and correct any soft foot.....	21
PT 3.5.2 - Measure and plot pre-alignment dimensions.....	24
PT 3.5.3 - Measure and record dial indicator sweep readings.....	26
PT 3.5.4 - Calculate and plot vertical offset.....	28
PT 3.5.5 - Calculate and plot horizontal offset.....	30
PT 3.5.6 - Correct coupling misalignment.....	32
PT 3.5.7 - Determine motor magnetic center.....	34
PT 3.5.8 - Measure and record final dial indicator readings.....	36
Information Sheet	38
IS 3.5.2 - Reverse dial indicator alignment method	38
Symptoms of misalignment.....	38
Soft foot correction	38
Vertical move	39
Horizontal move.....	39
Alignment Tolerances.....	40
IS 3.5.3 - Required equipment and tools.....	41

Reverse Dial Indicator Alignment

Table of Contents

Reference Materials	42
Self-Assessment	43
<i>SA 3.5 - Coupling alignment using reverse dial indicator.....</i>	<i>43</i>
Attachment A – Alignment Performance Worksheet	47

Reverse Dial Indicator Alignment

Competency 3.5

Terminal Objective

Align couplings using the reverse dial indicator method to within the vendor specified tolerance.

Enabling Objectives

- 3.5.1 Measure and correct any soft foot.
- 3.5.2 Measure and plot pre-alignment dimensions.
- 3.5.3 Measure and record dial indicator sweep readings.
- 3.5.4 Calculate and plot vertical offset.
- 3.5.5 Calculate and plot horizontal offset.
- 3.5.6 Correct coupling misalignment.
- 3.5.7 Measure and record final dial indicator readings.
- 3.5.8 Determine motor magnetic center.

Reverse Dial Indicator Alignment

Practice Exercise

PE 3.5.1 - Measure and correct any soft foot

Development Technician: _____ PIC: _____

Mentor/OJD Supervisor: _____ Date: _____

- 1 = Unskilled: Unable to satisfactorily perform.
- 2 = Limited Skill: Requires coaching and additional practice to satisfactorily perform.
- 3 = Skilled: Can perform to an acceptable standard.

Directions:

As part of the coupling alignment, measure and correct any soft foot.

1. Obtain Permit to Work and select the correct PPE, tools and equipment for the task. 1 2 3
2. Locate and refer to the manufacturer's manual/instructions. 1 2 3
3. Ensure any power supply is locked out and tagged out. 1 2 3
4. Determine the amount of soft foot for motor inboard foot 1 and shim as required. 1 2 3
 - Tighten all four motor bolts.
 - Clean the indicator contact areas on the motor inboard and outboard feet.
 - Attach the dial indicator on a clean surface of the motor mounting plate.
 - Place the point of the dial indicator on the cleaned surface of inboard foot 1.
 - Set the dial indicator at zero.
 - Loosen the bolts holding down inboard foot 1 and the opposite inboard foot 2.
 - Read the dial indicator and determine the amount of spring that occurred.
 - Insert shims under inboard foot 1 to take up the amount of spring.
 - Record the soft foot reading and final shims added on Attachment A.
 - Tighten all four motor bolts.
5. Determine the amount of soft foot for motor inboard foot 2 and shim as required. 1 2 3
 - Move the dial indicator to inboard foot 2.
 - Attach the dial indicator on a clean surface of the motor mounting plate.
 - Place the point of the dial indicator on the cleaned surface of inboard foot 2.
 - Set the dial indicator at zero.
 - Loosen the bolts holding down inboard foot 2 and the opposite inboard foot 1.
 - Read the dial indicator and determine the amount of spring that occurred.
 - Insert shims under inboard foot 2 to take up the amount of spring.
 - Record the soft foot reading and final shims added on Attachment A.
 - Tighten all four motor bolts.

Reverse Dial Indicator Alignment

Practice Exercise

PE 3.5.1 - Measure and correct any soft foot (cont.)

6. Determine the amount of soft foot for motor outboard foot 3. 1 2 3
- Move the dial indicator to outboard foot 3.
 - Attach the dial indicator on a clean surface of the motor mounting plate.
 - Place the point of the dial indicator on the cleaned surface of outboard foot 3.
 - Set the dial indicator at zero.
 - Loosen the bolts holding down outboard foot 3 and the opposite outboard foot 4.
 - Read the dial indicator and determine the amount of spring that occurred.
 - Insert shims under outboard foot 3 to take up the amount of spring.
 - Record the soft foot reading and final shims added on Attachment A.
 - Tighten all four motor bolts.
7. Determine the amount of soft foot for motor outboard foot 4. 1 2 3
- Move the dial indicator to outboard foot 4.
 - Attach the dial indicator on a clean surface of the motor mounting plate.
 - Place the point of the dial indicator on the cleaned surface of outboard foot 4.
 - Set the dial indicator at zero.
 - Loosen the bolts holding down outboard foot 4 and the opposite outboard foot 3.
 - Read the dial indicator and determine the amount of spring that occurred.
 - Insert shims under outboard foot 4 to take up the amount of spring.
 - Record the soft foot reading and final shims added on Attachment A.
 - Tighten all four motor bolts.

Overall Rating:

- Must repeat the Practice Exercise Approved for Performance Test

Evaluator Comments:

Mentor/OJD Supervisor Signature: _____

Development Technician Signature: _____

Reverse Dial Indicator Alignment

Practice Exercise

PE 3.5.2 - Measure and plot pre-alignment dimensions

Development Technician: _____ PIC: _____

Mentor/OJD Supervisor: _____ Date: _____

- 1 = Unskilled: Unable to satisfactorily perform.
- 2 = Limited Skill: Requires coaching and additional practice to satisfactorily perform.
- 3 = Skilled: Can perform to an acceptable standard.

Directions:

As part of the coupling alignment using the reverse indicator method, measure and plot the pre-alignment dimensions.

- | | | | |
|--|---|---|---|
| 1. Record equipment name and motor shaft diameter on Attachment A | 1 | 2 | 3 |
| 2. Remove coupling guard but do not break coupling at this time | 1 | 2 | 3 |
| 3. Measure for bar sag | 1 | 2 | 3 |
| – Determine coupling positions of indicators A and B | | | |
| – Measure distance between indicators and record as D1 on Attachment A | | | |
| – Select appropriate alignment fixtures needed. | | | |
| – Obtain a piece of pipe slightly longer than distance D1 and as close to shaft diameter as possible | | | |
| – Mount indicators with same mounting brackets that will be used for alignment at distance D1. | | | |
| – Zero out the indicators. | | | |
| – Roll pipe 180 degrees and read bottom indicator. | | | |
| – Record indicator readings. | | | |
| NOTE: Indicator sag will always read negative | | | |
| – Remove fixtures from pipe and install on the couplings. | | | |
| 4. Mount alignment fixtures on the equipment to be checked | 1 | 2 | 3 |

Reverse Dial Indicator Alignment

Practice Exercise

PE 3.5.2 - Measure and plot pre-alignment dimensions (cont.)

5. Plot D1, D2, D3 measurements 1 2 3
- Measure and record distance between indicators "A" and "B" (D1)
 - Measure and record distance between motor front foot and indicator "A" (D2)
 - Measure and record distance between motor back feet and indicator "A" (D3)
 - Select the "A" and "B" horizontal line on Attachment A
 - Place a round mark on the far right of this line representing the rear foot of the movable machine.
 - Count (left) the number of squares for each inch (D3) on the horizontal line and place a vertical mark (this represents indicator "A")
 - Count (right) the number squares for each inch (D2) on the horizontal line and place a round mark representing the front foot of the movable machine.
 - Count (right) again from the horizontal line of indicator "A" the number squares for D1 and place another horizontal mark representing indicator "B".

Overall Rating:

- Must repeat the Practice Exercise Approved for Performance Test

Evaluator Comments:

Mentor/OJD Supervisor Signature: _____

Development Technician Signature: _____

Reverse Dial Indicator Alignment

Practice Exercise

PE 3.5.3 - Measure and record dial indicator sweep readings

Development Technician: _____ PIC: _____

Mentor/OJD Supervisor: _____ Date: _____

- | | | | |
|---|---|----------------|--|
| 1 | = | Unskilled: | Unable to satisfactorily perform. |
| 2 | = | Limited Skill: | Requires coaching and additional practice to satisfactorily perform. |
| 3 | = | Skilled: | Can perform to an acceptable standard. |

Directions:

As part of the coupling alignment using the reverse indicator method, measure and record dial indicator sweep readings.

- | | | | |
|---|---|---|---|
| 1. Check dial indicator setup. | 1 | 2 | 3 |
| – Zero dial indicators at the top position for the “A” and “B” indicators. | | | |
| – Make a 360 degree sweep with dial indicators. | | | |
| – Verify that dial indicators “A” and “B” read zero at the top position. | | | |
| NOTE: If dial indicators do not zero, then check brackets and indicators for tightness and positioning. | | | |
| 2. Make a 360 degree sweep taking readings at 90 degree intervals for the “A” and “B” coupling. | 1 | 2 | 3 |
| – Record the measurements in the As-Found Reading section on Attachment A | | | |
| – Verify the total of side readings equal the bottom reading | | | |
| NOTE: If side readings do not equal bottom reading, then check alignment fixture for tightness and equipment shafts for axial movement | | | |

Reverse Dial Indicator Alignment

Practice Exercise

PE 3.5.3 - Measure and record dial indicator sweep readings (cont.)

Overall Rating:

Must repeat the Practice Exercise

Approved for Performance Test

Evaluator Comments:

Mentor/OJD Supervisor Signature: _____

Development Technician Signature: _____

Reverse Dial Indicator Alignment

Practice Exercise

PE 3.5.4 - Calculate and plot vertical offset

Development Technician: _____ PIC: _____

Mentor/OJD Supervisor: _____ Date: _____

- 1 = Unskilled: Unable to satisfactorily perform.
- 2 = Limited Skill: Requires coaching and additional practice to satisfactorily perform.
- 3 = Skilled: Can perform to an acceptable standard.

Directions:

As part of the coupling alignment using the reverse indicator method, calculate and plot vertical offset.

1. Calculate and record on Attachment A the vertical offset for the "A" dial indicator. 1 2 3
2. Calculate and record on Attachment A the vertical offset for the "B" dial indicator. 1 2 3
3. Plot point in the vertical plane of dial indicator "A" 1 2 3
 - Observe the sign plus or minus on the left hand portion of the sheet

NOTE: If the sign is +, then the plot will be marked above the desired shaft centerline line. If the sign is -, then the plot will be marked below the desired shaft centerline line
4. Plot point in the vertical plane of dial indicator "B" 1 2 3
 - Observe the sign plus or minus on the right hand portion of the sheet

NOTE: If the sign is +, then the plot will be marked below the desired shaft centerline line. If the sign is -, then the plot will be marked above the desired shaft centerline line
5. Using a straight edge, draw a line connecting the two points (A and B) plotted for vertical offset. 1 2 3
 - Extend the line past the vertical plane on the graph for the motor rear foot (D3)

NOTE: If the line goes off the graph before it crosses the vertical line at the feet, then reposition the original line in a different area of the graph paper or use larger graph paper.
6. Determine the amount of vertical offset. 1 2 3

Reverse Dial Indicator Alignment

Practice Exercise

PE 3.5.4 - Calculate and plot vertical offset (cont.)

Overall Rating:

Must repeat the Practice Exercise

Approved for Performance Test

Evaluator Comments:

Mentor/OJD Supervisor Signature: _____

Development Technician Signature: _____

Reverse Dial Indicator Alignment

Practice Exercise

PE 3.5.5 - Calculate and plot horizontal offset

Development Technician: _____ PIC: _____

Mentor/OJD Supervisor: _____ Date: _____

- 1 = Unskilled: Unable to satisfactorily perform.
- 2 = Limited Skill: Requires coaching and additional practice to satisfactorily perform.
- 3 = Skilled: Can perform to an acceptable standard.

Directions:

As part of the coupling alignment using the reverse indicator method, calculate and plot horizontal offset.

1. Calculate and record on Attachment A the horizontal offset for the "A" dial indicator. 1 2 3
2. Calculate and record on Attachment A the horizontal offset for the "B" dial indicator. 1 2 3
3. Plot point in the horizontal plane of dial indicator "A" 1 2 3
 - Observe the sign plus or minus on the left hand portion of the sheet
 - NOTE:** If the sign is +, then the plot will be marked above the desired shaft centerline line. If the sign is -, then the plot will be marked below the desired shaft centerline line
4. Plot point in the horizontal plane of dial indicator "B" 1 2 3
 - Observe the sign plus or minus on the right hand portion of the sheet
 - NOTE:** If the sign is +, then the plot will be marked below the desired shaft centerline line. If the sign is -, then the plot will be marked above the desired shaft centerline line
5. Using a straight edge, draw a line connecting the two points (A and B) plotted for horizontal offset. 1 2 3
 - Extend the line past the horizontal plane on the graph for the motor rear foot (D3)
6. Determine the amount of horizontal offset. 1 2 3

Reverse Dial Indicator Alignment

Practice Exercise

PE 3.5.5 - Calculate and plot horizontal offset (cont.)

Overall Rating:

Must repeat the Practice Exercise

Approved for Performance Test

Evaluator Comments:

Mentor/OJD Supervisor Signature: _____

Development Technician Signature: _____

Reverse Dial Indicator Alignment

Practice Exercise

PE 3.5.6 - Correct coupling misalignment

Development Technician: _____ PIC: _____

Mentor/OJD Supervisor: _____ Date: _____

- 1 = **Unskilled:** **Unable to satisfactorily perform.**
- 2 = **Limited Skill:** **Requires coaching and additional practice to satisfactorily perform.**
- 3 = **Skilled:** **Can perform to an acceptable standard.**

Directions:

As part of the coupling alignment, correct coupling misalignment.

- | | | | |
|---|---|---|---|
| 1. Disassemble the coupling | 1 | 2 | 3 |
| – Measure and record gap on Attachment A | | | |
| 3. Check shaft run out for “A” and “B” and record on Attachment A | 1 | 2 | 3 |
| 4. Measure motor shaft end play and record on Attachment A | 1 | 2 | 3 |
| 5. Measure pump shaft end play and record on Attachment A | 1 | 2 | 3 |
| 6. Correct vertical misalignment. | 1 | 2 | 3 |
| – Loosen motor base bolts. | | | |
| – Add or remove shims under the feet as required. | | | |
| – Tighten bolts and recheck alignment. | | | |
| 7. Correct horizontal misalignment | 1 | 2 | 3 |
| – Loosen motor base bolts. | | | |
| – Move the motor to the left or right as required. | | | |
| – Tighten bolts and recheck alignment. | | | |

Reverse Dial Indicator Alignment

Practice Exercise

PE 3.5.6 - Correct coupling misalignment (cont.)

Overall Rating:

Must repeat the Practice Exercise

Approved for Performance Test

Evaluator Comments:

Mentor/OJD Supervisor Signature: _____

Development Technician Signature: _____

Reverse Dial Indicator Alignment

Practice Exercise

PE 3.5.7 - Determine motor magnetic center

Development Technician: _____ PIC: _____

Mentor/OJD Supervisor: _____ Date: _____

- 1 = Unskilled: Unable to satisfactorily perform.
- 2 = Limited Skill: Requires coaching and additional practice to satisfactorily perform.
- 3 = Skilled: Can perform to an acceptable standard.

Directions:

As part of the coupling alignment, determine motor magnetic center (only required for journal bearings without thrust bearing applications).

1. Secure coupling flange so it will not contact rotating shaft/coupling hub during operation. 1 2 3
2. Apply Dykem layout dye or equivalent to motor shaft in area where magnetic center is to be marked. 1 2 3
NOTE: Notify operations to start the motor.
3. Using a scribe, mark magnetic center on motor shaft. 1 2 3
NOTE: Notify operations to stop the motor.
4. Measure the distance between the scribed mark and the outside bearing housing lip and record on Attachment A. 1 2 3
5. If the magnetic center scribe mark falls inside the motor housing, then scribe a mark in the rest position. 1 2 3
 - Run the motor and estimate the difference between the newly scribed mark and the magnetic center mark.
 - Record measurement on Attachment A.
6. Set the coupling face gap. 1 2 3
 - Measure the gap between the coupling halves using a scale, feeler gauge, taper or an inside micrometer.
 - Compare the as-found gap with the manufacturer's specifications.
 - Minus the distance measured for the magnet center correction if the mark is outside the bearing housing.
 - Add the difference measured for the magnet center correction if the mark is inside the bearing housing.
 - Set the proper face gap by moving the motor backward or forward.
 - Tighten the motor mount bolts.

Reverse Dial Indicator Alignment

Practice Exercise

PE 3.5.7 - Determine motor magnetic center (cont.)

Overall Rating:

Must repeat the Practice Exercise

Approved for Performance Test

Evaluator Comments:

Mentor/OJD Supervisor Signature: _____

Development Technician Signature: _____

Reverse Dial Indicator Alignment

Practice Exercise

PE 3.5.8 - Measure and record final dial indicator readings

Development Technician: _____ PIC: _____

Mentor/OJD Supervisor: _____ Date: _____

- 1 = Unskilled: Unable to satisfactorily perform.
- 2 = Limited Skill: Requires coaching and additional practice to satisfactorily perform.
- 3 = Skilled: Can perform to an acceptable standard.

Directions:

As part of the coupling alignment, measure and record final dial indicator readings.

- | | | | |
|--|---|---|---|
| 1. Ensure motor mounting bolts are tight. | 1 | 2 | 3 |
| 2. Take a final set of dial indicator readings and record on Attachment A. | 1 | 2 | 3 |
| 3. Calculate final vertical offset for the A and B dial indicator positions and record on Attachment A | 1 | 2 | 3 |
| 4. Calculate final horizontal offset for the A and B dial indicator positions and record on Attachment A | 1 | 2 | 3 |
| 5. Verify the numbers are acceptable | 1 | 2 | 3 |
| 6. Re-couple the shafts. | 1 | 2 | 3 |
| 7. Replace coupling guard | 1 | 2 | 3 |

Reverse Dial Indicator Alignment

Practice Exercise

PE 3.5.2 - Measure and record final dial indicator readings (cont.)

Overall Rating:

Must repeat the Practice Exercise

Approved for Performance Test

Evaluator Comments:

Mentor/OJD Supervisor Signature: _____

Development Technician Signature: _____

Reverse Dial Indicator Alignment

Performance Test

PT 3.5.1 - Measure and correct any soft foot

Development Technician: _____ PIC: _____

Mentor/OJD Supervisor: _____ Date: _____

Yes = Skilled: Can perform to an acceptable standard.

No = Unskilled: Unable to satisfactorily perform.

N/A = Not Applicable: Some of the performance standards may not be applicable when the Performance Test is carried out under simulated conditions.

Directions:

As part of the coupling alignment, measure and correct any soft foot.

Performance Standards

- | | | | |
|--|-----|----|-----|
| 1. Obtain Permit to Work and select the correct PPE, tools and equipment for the task. | Yes | No | N/A |
| 2. Locate and refer to the manufacturer's manual/instructions. | Yes | No | N/A |
| 3. Ensure any power supply is locked out and tagged out. | Yes | No | N/A |
| 4. Determine the amount of soft foot for motor inboard foot 1 and shim as required. | Yes | No | N/A |
| – Tighten all four motor bolts. | | | |
| – Clean the indicator contact areas on the motor inboard and outboard feet. | | | |
| – Attach the dial indicator on a clean surface of the motor mounting plate. | | | |
| – Place the point of the dial indicator on the cleaned surface of inboard foot 1. | | | |
| – Set the dial indicator at zero. | | | |
| – Loosen the bolts holding down inboard foot 1 and the opposite inboard foot 2. | | | |
| – Read the dial indicator and determine the amount of spring that occurred. | | | |
| – Insert shims under inboard foot 1 to take up the amount of spring. | | | |
| – Record the soft foot reading and final shims added on Attachment A. | | | |
| – Tighten all four motor bolts. | | | |

Reverse Dial Indicator Alignment

Performance Test

PT 3.5.1 - Measure and correct any soft foot (cont.)

- | | | | | |
|----|--|-----|----|-----|
| 5. | Determine the amount of soft foot for motor inboard foot 2 and shim as required. | Yes | No | N/A |
| | – Move the dial indicator to inboard foot 2. | | | |
| | – Attach the dial indicator on a clean surface of the motor mounting plate. | | | |
| | – Place the point of the dial indicator on the cleaned surface of inboard foot 2. | | | |
| | – Set the dial indicator at zero. | | | |
| | – Loosen the bolts holding down inboard foot 2 and the opposite inboard foot 1. | | | |
| | – Read the dial indicator and determine the amount of spring that occurred. | | | |
| | – Insert shims under inboard foot 2 to take up the amount of spring. | | | |
| | – Record the soft foot reading and final shims added on Attachment A. | | | |
| | – Tighten all four motor bolts. | | | |
| 6. | Determine the amount of soft foot for motor outboard foot 3. | Yes | No | N/A |
| | – Move the dial indicator to outboard foot 3. | | | |
| | – Attach the dial indicator on a clean surface of the motor mounting plate. | | | |
| | – Place the point of the dial indicator on the cleaned surface of outboard foot 3. | | | |
| | – Set the dial indicator at zero. | | | |
| | – Loosen the bolts holding down outboard foot 3 and the opposite outboard foot 4. | | | |
| | – Read the dial indicator and determine the amount of spring that occurred. | | | |
| | – Insert shims under outboard foot 3 to take up the amount of spring. | | | |
| | – Record the soft foot reading and final shims added on Attachment A. | | | |
| | – Tighten all four motor bolts. | | | |
| 7. | Determine the amount of soft foot for motor outboard foot 4. | Yes | No | N/A |
| | – Move the dial indicator to outboard foot 4. | | | |
| | – Attach the dial indicator on a clean surface of the motor mounting plate. | | | |
| | – Place the point of the dial indicator on the cleaned surface of outboard foot 4. | | | |
| | – Set the dial indicator at zero. | | | |
| | – Loosen the bolts holding down outboard foot 4 and the opposite outboard foot 3. | | | |
| | – Read the dial indicator and determine the amount of spring that occurred. | | | |
| | – Insert shims under outboard foot 4 to take up the amount of spring. | | | |
| | – Record the soft foot reading and final shims added on Attachment A. | | | |
| | – Tighten all four motor bolts. | | | |

Reverse Dial Indicator Alignment

Performance Test

PT 3.5.1 - Measure and correct any soft foot (cont.)

Overall Rating:

Pass

Fail

Evaluator Comments:

Mentor/OJD Supervisor Signature: _____

Development Technician Signature: _____

Reverse Dial Indicator Alignment

Performance Test

PT 3.5.2 - Measure and plot pre-alignment dimensions

Development Technician: _____ PIC: _____

Mentor/OJD Supervisor: _____ Date: _____

Yes = Skilled: Can perform to an acceptable standard.

No = Unskilled: Unable to satisfactorily perform.

N/A = Not Applicable: Some of the performance standards may not be applicable when the Performance Test is carried out under simulated conditions.

Directions:

As part of the coupling alignment using the reverse indicator method, measure and plot the pre-alignment dimensions.

Performance Standards

- | | | | |
|--|-----|----|-----|
| 1. Record equipment name and motor shaft diameter on Attachment A | Yes | No | N/A |
| 2. Remove coupling guard but do not break coupling at this time | Yes | No | N/A |
| 3. Measure for bar sag | Yes | No | N/A |
| – Determine coupling positions of indicators A and B | | | |
| – Measure distance between indicators and record as D1 on Attachment A | | | |
| – Select appropriate alignment fixtures needed. | | | |
| – Obtain a piece of pipe slightly longer than distance D1 and as close to shaft diameter as possible | | | |
| – Mount indicators with same mounting brackets that will be used for alignment at distance D1. | | | |
| – Zero out the indicators. | | | |
| – Roll pipe 180 degrees and read bottom indicator. | | | |
| – Record indicator readings. | | | |
| NOTE: Indicator sag will always read negative | | | |
| – Remove fixtures from pipe and install on the couplings. | | | |
| 4. Mount alignment fixtures on the equipment to be checked | Yes | No | N/A |

Reverse Dial Indicator Alignment

Performance Test

PT 3.5.2 - Measure and plot pre-alignment dimensions (cont.)

5. Plot D1, D2, D3 measurements

Yes No N/A

- Measure and record distance between indicators "A" and "B" (D1)
- Measure and record distance between motor front foot and indicator "A" (D2)
- Measure and record distance between motor back feet and indicator "A" (D3)
- Select the "A" and "B" horizontal line on Attachment A
- Place a round mark on the far right of this line representing the rear foot of the movable machine.
- Count (left) the number of squares for each inch (D3) on the horizontal line and place a vertical mark (this represents indicator "A")
- Count (right) the number squares for each inch (D2) on the horizontal line and place a round mark representing the front foot of the movable machine.
- Count (right) again from the horizontal line of indicator "A" the number squares for D1 and place another horizontal mark representing indicator "B".

Overall Rating:

Pass

Fail

Evaluator Comments:

Mentor/OJD Supervisor Signature: _____

Development Technician Signature: _____

Reverse Dial Indicator Alignment

Performance Test

PT 3.5.3 - Measure and record dial indicator sweep readings

Development Technician: _____ PIC: _____

Mentor/OJD Supervisor: _____ Date: _____

Yes = Skilled: Can perform to an acceptable standard.

No = Unskilled: Unable to satisfactorily perform.

N/A = Not Applicable: Some of the performance standards may not be applicable when the Performance Test is carried out under simulated conditions.

Directions:

As part of the coupling alignment using the reverse indicator method, measure and record dial indicator sweep readings.

Performance Standards

- | | | | |
|--|-----|----|-----|
| 1. Check dial indicator setup. | Yes | No | N/A |
| – Zero dial indicators at the top position for the “A” and “B” indicators. | | | |
| – Make a 360 degree sweep with dial indicators. | | | |
| – Verify that dial indicators “A” and “B” read zero at the top position. | | | |

NOTE: If dial indicators do not zero, then check brackets and indicators for tightness and positioning.

- | | | | |
|---|-----|----|-----|
| 2. Make a 360 degree sweep taking readings at 90 degree intervals for the “A” and “B” coupling. | Yes | No | N/A |
| – Record the measurements in the As-Found Reading section on Attachment A | | | |
| – Verify the total of side readings equal the bottom reading | | | |

NOTE: If side readings do not equal bottom reading, then check alignment fixture for tightness and equipment shafts for axial movement

Reverse Dial Indicator Alignment

Performance Test

PT 3.5.3 - Measure and record dial indicator sweep readings (cont.)

Overall Rating:

Pass

Fail

Evaluator Comments:

Mentor/OJD Supervisor Signature: _____

Development Technician Signature: _____

Reverse Dial Indicator Alignment

Performance Test

PT 3.5.4 - Calculate and plot vertical offset

Development Technician: _____ PIC: _____

Mentor/OJD Supervisor: _____ Date: _____

- Yes = Skilled: Can perform to an acceptable standard.
- No = Unskilled: Unable to satisfactorily perform.
- N/A = Not Applicable: Some of the performance standards may not be applicable when the Performance Test is carried out under simulated conditions.

Directions:

As part of the coupling alignment using the reverse indicator method, calculate and plot vertical offset.

Performance Standards

- | | | | |
|---|-----|----|-----|
| 1. Calculate and record on Attachment A the vertical offset for the "A" dial indicator. | Yes | No | N/A |
| 2. Calculate and record on Attachment A the vertical offset for the "B" dial indicator. | Yes | No | N/A |
| 3. Plot point in the vertical plane of dial indicator "A"
– Observe the sign plus or minus on the left hand portion of the sheet
NOTE: If the sign is +, then the plot will be marked above the desired shaft centerline line. If the sign is -, then the plot will be marked below the desired shaft centerline line | Yes | No | N/A |
| 4. Plot point in the vertical plane of dial indicator "B"
– Observe the sign plus or minus on the right hand portion of the sheet
NOTE: If the sign is +, then the plot will be marked below the desired shaft centerline line. If the sign is -, then the plot will be marked above the desired shaft centerline line | Yes | No | N/A |
| 5. Using a straight edge, draw a line connecting the two points (A and B) plotted for vertical offset.
– Extend the line past the vertical plane on the graph for the motor rear foot (D3)
NOTE: If the line goes off the graph before it crosses the vertical line at the feet, then reposition the original line in a different area of the graph paper or use larger graph paper. | Yes | No | N/A |
| 6. Determine the amount of vertical offset. | Yes | No | N/A |

Reverse Dial Indicator Alignment

Performance Test

PT 3.5.4 - Calculate and plot vertical offset (cont.)

Overall Rating:

Pass

Fail

Evaluator Comments:

Mentor/OJD Supervisor Signature: _____

Development Technician Signature: _____

Reverse Dial Indicator Alignment

Performance Test

PT 3.5.5 - Calculate and plot horizontal offset

Development Technician: _____ PIC: _____

Mentor/OJD Supervisor: _____ Date: _____

- Yes = Skilled: Can perform to an acceptable standard.
- No = Unskilled: Unable to satisfactorily perform.
- N/A = Not Applicable: Some of the performance standards may not be applicable when the Performance Test is carried out under simulated conditions.

Directions:

As part of the coupling alignment using the reverse indicator method, calculate and plot horizontal offset.

Performance Standards

- | | | | |
|---|-----|----|-----|
| 1. Calculate and record on Attachment A the horizontal offset for the "A" dial indicator. | Yes | No | N/A |
| 2. Calculate and record on Attachment A the horizontal offset for the "B" dial indicator. | Yes | No | N/A |
| 3. Plot point in the horizontal plane of dial indicator "A"
– Observe the sign plus or minus on the left hand portion of the sheet
NOTE: If the sign is +, then the plot will be marked above the desired shaft centerline line. If the sign is -, then the plot will be marked below the desired shaft centerline line | Yes | No | N/A |
| 4. Plot point in the horizontal plane of dial indicator "B"
– Observe the sign plus or minus on the right hand portion of the sheet
NOTE: If the sign is +, then the plot will be marked below the desired shaft centerline line. If the sign is -, then the plot will be marked above the desired shaft centerline line | Yes | No | N/A |
| 5. Using a straight edge, draw a line connecting the two points (A and B) plotted for horizontal offset.
– Extend the line past the horizontal plane on the graph for the motor rear foot (D3) | Yes | No | N/A |
| 6. Determine the amount of horizontal offset. | Yes | No | N/A |

Reverse Dial Indicator Alignment

Performance Test

PT 3.5.5 - Calculate and plot horizontal offset (cont.)

Overall Rating:

Pass

Fail

Evaluator Comments:

Mentor/OJD Supervisor Signature: _____

Development Technician Signature: _____

Reverse Dial Indicator Alignment

Performance Test

PT 3.5.6 - Correct coupling misalignment

Development Technician: _____ PIC: _____

Mentor/OJD Supervisor: _____ Date: _____

Yes = Skilled: Can perform to an acceptable standard.

No = Unskilled: Unable to satisfactorily perform.

N/A = Not Applicable: Some of the performance standards may not be applicable when the Performance Test is carried out under simulated conditions.

Directions:

As part of the coupling alignment, correct coupling misalignment.

Performance Standards

- | | | | |
|--|-----|----|-----|
| 1. Disassemble the coupling
Measure and record gap on Attachment A | Yes | No | N/A |
| 3. Check shaft run out for "A" and "B" and record on Attachment A | Yes | No | N/A |
| 4. Measure motor shaft end play and record on Attachment A | Yes | No | N/A |
| 5. Measure pump shaft end play and record on Attachment A | Yes | No | N/A |
| 6. Correct vertical misalignment.
– Loosen motor base bolts.
– Add or remove shims under the feet as required.
– Tighten bolts and recheck alignment. | Yes | No | N/A |
| 7. Correct horizontal misalignment
– Loosen motor base bolts.
– Move the motor to the left or right as required.
– Tighten bolts and recheck alignment. | Yes | No | N/A |

Reverse Dial Indicator Alignment

Performance Test

PT 3.5.6 - Correct coupling misalignment (cont.)

- | | Yes | No | N/A |
|--|-----|----|-----|
| 6. Set the coupling face gap. | | | |
| – Measure the gap between the coupling halves using a scale, feeler gauge, taper or an inside micrometer. | | | |
| – Compare the as-found gap with the manufacturer's specifications. | | | |
| – Minus the distance measured for the magnet center correction if the mark is outside the bearing housing. | | | |
| – Add the difference measured for the magnet center correction if the mark is inside the bearing housing. | | | |
| – Set the proper face gap by moving the motor backward or forward. | | | |
| – Tighten the motor mount bolts. | | | |

Overall Rating:

Pass

Fail

Evaluator Comments:

Mentor/OJD Supervisor Signature: _____

Development Technician Signature: _____

Reverse Dial Indicator Alignment

Performance Test

PT 3.5.7 - Determine motor magnetic center

Development Technician: _____ PIC: _____

Mentor/OJD Supervisor: _____ Date: _____

Yes = Skilled: Can perform to an acceptable standard.

No = Unskilled: Unable to satisfactorily perform.

N/A = Not Applicable: Some of the performance standards may not be applicable when the Performance Test is carried out under simulated conditions.

Directions:

As part of the coupling alignment, determine motor magnetic center

NOTE: Only required for motors with journal bearings.

Performance Standards

- | | | | |
|--|-----|----|-----|
| 1. Secure coupling flange so it will not contact rotating shaft/coupling hub during operation. | Yes | No | N/A |
| 2. Apply Dykem layout dye or equivalent to motor shaft in area where magnetic center is to be marked. | Yes | No | N/A |
| NOTE: Notify operations to start the motor. | | | |
| 3. Using a scribe, mark magnetic center on motor shaft. | Yes | No | N/A |
| NOTE: Notify operations to stop the motor. | | | |
| 4. Measure the distance between the scribed mark and the outside bearing housing lip and record on Attachment A. | Yes | No | N/A |
| 5. If the magnetic center scribe mark falls inside the motor housing, then scribe a mark in the rest position. | Yes | No | N/A |
| – Run the motor and estimate the difference between the newly scribed mark and the magnetic center mark. | | | |
| – Record measurement on Attachment A. | | | |

Reverse Dial Indicator Alignment

Performance Test

PT 3.5.7 - Determine motor magnetic center (cont.)

Overall Rating:

Pass

Fail

Evaluator Comments:

Mentor/OJD Supervisor Signature: _____

Development Technician Signature: _____

Reverse Dial Indicator Alignment

Performance Test

PT 3.5.8 - Measure and record final dial indicator readings

Development Technician: _____ PIC: _____

Mentor/OJD Supervisor: _____ Date: _____

Yes = Skilled: Can perform to an acceptable standard.

No = Unskilled: Unable to satisfactorily perform.

N/A = Not Applicable: Some of the performance standards may not be applicable when the Performance Test is carried out under simulated conditions.

Directions:

As part of the coupling alignment, measure and record final dial indicator readings.

Performance Standards

- | | | | |
|--|-----|----|-----|
| 1. Ensure motor mounting bolts are tight. | Yes | No | N/A |
| 2. Take a final set of dial indicator readings and record on Attachment A. | Yes | No | N/A |
| 3. Calculate final vertical offset for the A and B dial indicator positions and record on Attachment A | Yes | No | N/A |
| 4. Calculate final horizontal offset for the A and B dial indicator positions and record on Attachment A | Yes | No | N/A |
| 5. Verify the numbers are acceptable | Yes | No | N/A |
| 6. Re-couple the shafts. | Yes | No | N/A |
| 7. Replace coupling guard | Yes | No | N/A |

Reverse Dial Indicator Alignment

Performance Test

PT 3.5.8 - Measure and record final dial indicator readings (cont.)

Overall Rating:

Pass

Fail

Evaluator Comments:

Mentor/OJD Supervisor Signature: _____

Development Technician Signature: _____

Reverse Dial Indicator Alignment

Information Sheet

IS 3.5.2 - Reverse dial indicator alignment method

Reverse Indicator Method (RIM) is the most accurate method of performing alignment between two direct-coupled shafts. Even the laser technique is based upon RIM. The real value lies in being able to perform alignment without using sophisticated tools while achieving the same accuracy. This is achieved through only training and knowledge.

Symptoms of misalignment

Misalignment is not easy to detect on machinery that is running. Misalignment will be only obvious through secondary effects of the following symptoms:

- Premature bearing, seal, shaft, or coupling failures
NOTE: Some flexible coupling designs run hot under misalignment conditions. If it is an elastomeric type, look for rubber powder inside the coupling
- Excessive vibration
- High casing temperatures at or near the bearings or high oil temperatures
- Excessive amount of oil leakage at the bearing seals
- Loose foundation bolts
- Loose or broken coupling bolts
- Unusually high number of coupling failures or they wear quickly
- The shafts are breaking (or cracking) at or close to the inboard bearings or coupling hubs

Soft foot correction

A soft foot is caused when one or more of the machine feet do not rest firmly on the base plate. Soft foot is a condition that could cause a lot of problem with repeatability in the positioning of the machine during the alignment process. When a machine with a soft foot is bolted down to the base, the machine casing is exposed to tension forces. This can affect bearing positions and result in the premature wear of bearing and other machine components.

One type of soft foot is called "short foot" or "parallel soft foot". This problem is solved by adding shims to the "short foot".

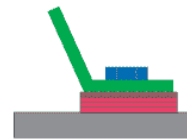

A second type of soft foot occurs as "angled foot". It can be solved by adding shims under the foot as shown to the right, but it is better to correct the angle of the foot or making a steel wedge.

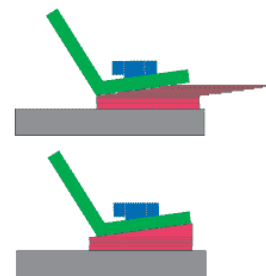

Reverse Dial Indicator Alignment

Information Sheet

PT 3.5.8 - Reverse dial indicator alignment method (cont.)

Vertical move

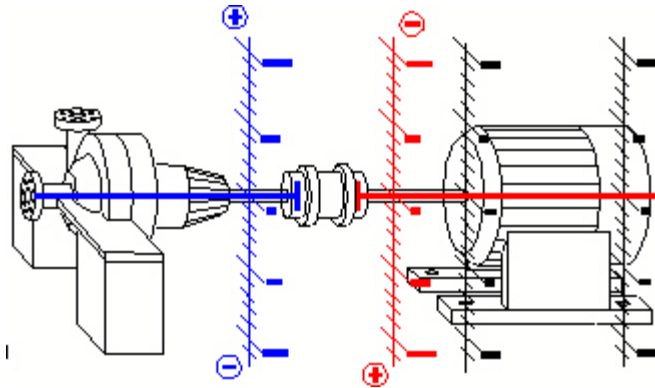

The vertical move is the part of the alignment process that aligns the two shaft's centerlines into their proper up and down position. Usually you will have to add or remove shims in this step. The indicators are zeroed on the top and read at the bottom. Start with a plus + reading if you need to compensate for sag.

Horizontal move

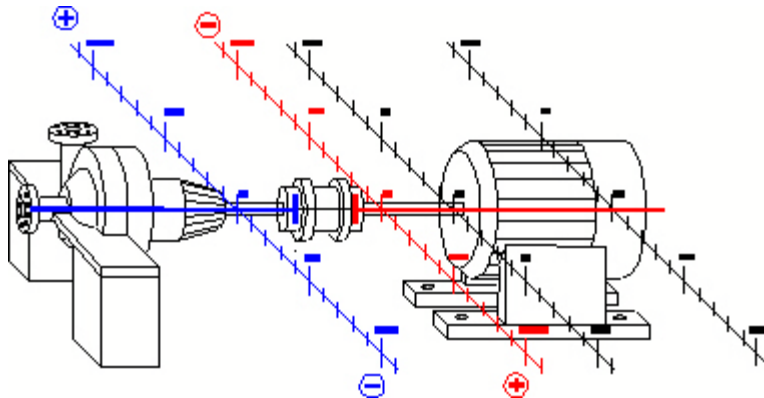

The horizontal move is the part of the alignment process that aligns the shaft's centerlines from side to side. View the machine from the pump end, zero the indicators on the left, and then rotate and read on the right. Make sure that you always view the pump from the same direction in order for you to keep the left and right directions correct. There is no sag compensation on the horizontal move.

Reverse Dial Indicator Alignment

Information Sheet

PT 3.5.8 - Reverse dial indicator alignment method (cont.)

Alignment Tolerances

These suggested tolerances are the maximum allowable deviations from desired values (targets), whether such values are zero or nonzero. These recommended tolerances should be used in the absence of in-house specifications or tighter tolerances from the machinery manufacturer.

RPM	Short Couplings						Spacer Shafts	
	Excellent			Acceptable			Excellent	Acceptable
	Offset	Angularity		Offset	Angularity		(mils of offset per inch of space length) (or spacer to shaft angle)	
	(mils)	(mils)	(mils)	(mils)	(mils)	(mils)		
	(inch)	(10")		(inch)	(10")			
600	5.0	1.0	10.0	9.0	1.5	15.0	1.8	3.0
900	3.0	0.7	7.0	6.0	1.0	10.0	1.2	2.0
1200	2.5	0.5	5.0	4.0	0.8	8.0	0.9	1.5
1800	2.0	0.3	3.0	3.0	0.5	5.0	0.6	1.0
3600	1.0	0.2	2.0	1.5	0.3	3.0	0.3	0.5
7200	0.5	0.1	1.0	1.0	0.2	2.0	0.15	0.25

Reverse Dial Indicator Alignment

Information Sheet

IS 3.5.3 - Required equipment and tools

Equipment:

The tools and equipment you will typically need to align couplings:

- Dial indicators (0.000" - 1.000") and mounting brackets
- Feeler gauges
- Mandrill or pipe to determine bar sag
- Micrometer (0.000" - 1.000")
- Pencil and paper
- Scotchbrite®
- Shim Pack
- Standard issue tool box
- Straight edge

NOTE: If you cannot locate any of the Equipment or Tools, ask your Mentor or On-the-Job Development Supervisor.

Reverse Dial Indicator Alignment

Reference Materials

Listed below are the documents you will need to prepare for your Practice Exercises and Performance Tests.

<u>Reference Materials</u>	<u>Document No. / Type</u>	<u>Location</u>

NOTE: If you cannot locate any of the Reference Materials ask a Mentor or your On-the-Job Development Supervisor.

Reverse Dial Indicator Alignment

Self-Assessment

SA 3.5 - Coupling alignment using reverse dial indicator

1. **Q. Reverse dial indicator alignment is defined as:**
 - A. Using 2 dial indicators, one on either side of each machine's faces.
 - B. Using 2 dial indicators on each machine's face and calculating the misalignment from those readings.
 - C. Using 2 dial indicators, and inverting the readings so that they apply directly to each machine's shaft.
 - D. Using 2 dial indicators on each machine's rim and calculating the misalignment from those readings.

A. D. Using 2 dial indicators on each machine's rim and calculating the misalignment from those readings

2. **Q. Which of the following is true of the dial readings for indicator bar sag?**
 - A. Sag on the "A" dial is negative, sag on the "B" dial is positive
 - B. Indicator bar sag is always positive
 - C. Indicator bar sag is always negative
 - D. Sag on the "A" dial is positive, sag on the "B" dial is negative

A. C. Indicator bar sag is always negative

3. **Q. Which type of misalignment always requires the addition or subtraction of shims?**
 - A. Parallel misalignment
 - B. Vertical misalignment
 - C. Angular misalignment
 - D. Skewed misalignment

A. B. Vertical misalignment

Reverse Dial Indicator Alignment

Self-Assessment

SA 3.5. - Coupling alignment using reverse dial indicator (cont.)

4. Q. During an alignment procedure, a mechanic determines that the motor's coupling hub is 24 mils lower than the pump's hub. Select the choice that best describes how shims should be used to correct the gap.
- A. Insert 24 mils at coupling end and 24 mils at back end.
 - B. Insert 24 mils at coupling end, none at back end.
 - C. Insert 24 mils at back end, none at coupling end.
 - D. Insert 12 mils at coupling end and 12 mils at back end.
- A. A. Insert 24 mils at coupling end and 24 mils at back end.
5. Q. During a reverse dial procedure, the dial indicators were set to compensate for bar sag and the shafts were rotated to measure misalignment in the vertical plane. If the dial indicator at the 6 o'clock position reads +6 mils, what is the vertical misalignment measured by the indicator?
- A. +3 mils
 - B. +6 mils
 - C. -3 mils
 - D. -6 mils
- A. A. +3 mils
6. Q. Suppose your calculations showed that, to correct for misalignment, you had to remove .008" shim from both the front and back feet. But the technical manual states that you must allow for .004" heat rise on the stationary machine. How much total shim should you add or subtract from the movable machine?
- A. Subtract .012"
 - B. Add .012"
 - C. Subtract .004"
 - D. Add .004"
- A. C. Subtract .004"

Reverse Dial Indicator Alignment

Self-Assessment

SE 3.5. - Coupling alignment using reverse dial indicator (cont.)

7. **Q. How is end thrust measured on a machine?**
- A. Run the machine until hot, then mark the shaft
 - B. Subtract the magnetic center of the motor from the fully extended position
 - C. Subtract the specified coupling gap from the true coupling gap
 - D. Measure the distance between the shaft pushed in versus pushed out
- A.** D. Measure the distance between the shaft pushed in versus pushed out
8. **Q. What must be maintained to prevent damage to a coupling from axial movement of the shafts?**
- A. Collinear run out
 - B. The proper face gap
 - C. Adequate pipe strain
 - D. Ample soft foot
- A.** B. The proper face gap
9. **Q. Which of these measurements is most likely to be used to determine if a shaft or bearing problem exists on a piece of rotating equipment?**
- A. Run out readings
 - B. Magnetic center settings
 - C. Soft foot specifications
 - D. Thermal growth calculations
- A.** A. Run out readings

Reverse Dial Indicator Alignment

Self-Assessment

SE 3.5. - Coupling alignment using reverse dial indicator (cont.)

10. Q. After brackets and dial indicators are attached to a pump and motor, and each indicator is adjusted, how is vertical misalignment measured using the reverse dial method?
- A. Rotate motor shaft only, 90 degrees.
 - B. Rotate both shafts 180 degrees.
 - C. Rotate pump shaft only, 270 degrees.
 - D. Rotate motor shaft only, 360 degrees.
- A. B. Rotate both shafts 180 degrees.

Next Step:

Review your answers to the questions with your Mentor or On-the-Job Development Supervisor. If you have answered all of the questions correctly, you are ready to begin your Practice Exercises.

Attachment A – Alignment Performance Worksheet

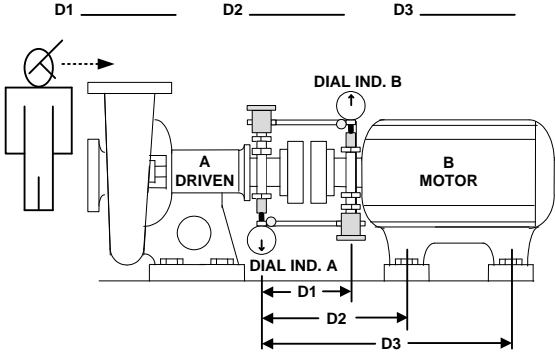
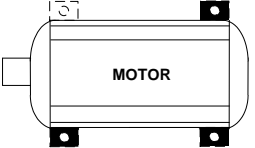
REVERSE, DIAL INDICATOR METHOD			ALIGNMENT PERFORMANCE WORKSHEET	
<p style="text-align: center; margin: 0;">AS-FOUND READING</p> <p>T 1. _____ .000" T 2. _____ .000"</p> <p>L 1. _____ (A) _____ R 1. L 2. _____ (B) _____ R 2.</p> <p>B 1. _____ B 2. _____</p>	<p style="text-align: center; margin: 0;">CALCULATE AS-FOUND OFFSET = $\frac{B - (SAG)}{2}$</p> <p>VERTICAL OFFSET: ACTUAL VERTICAL READING: A _____</p> <p>ACTUAL VERTICAL READING: B _____</p>	<p style="text-align: center; margin: 0;">CALCULATE AS-FOUND OFFSET = $\frac{R - L}{2}$</p> <p>HORIZONTAL OFFSET: ACTUAL HORIZONTAL READING: A _____</p> <p>ACTUAL HORIZONTAL READING: B _____</p>	<p>EQUIPMENT NAME: _____</p> <p>MOTOR SHAFT DIAMETER: _____</p> <p>UNCOUPLED SHAFT RUNOUT – A: _____</p> <p>UNCOUPLED SHAFT RUNOUT – B: _____</p> <p>MOTOR SHAFT END PLAY: _____</p> <p>PUMP SHAFT END PLAY: _____</p> <p>COUPLING GAP: _____ AS-FOUND _____ AS-LEFT</p>	
<p style="text-align: center; margin: 0;">FINAL READING</p> <p>T 3. _____ .000" T 4. _____ .000"</p> <p>L 3. _____ (A) _____ R 3. L 4. _____ (B) _____ R 4.</p> <p>B 3. _____ B 4. _____</p>	<p style="text-align: center; margin: 0;">CALCULATE FINAL OFFSET = $\frac{B - (SAG)}{2}$</p> <p>VERTICAL OFFSET: ACTUAL VERTICAL READING: A _____</p> <p>ACTUAL VERTICAL READING: B _____</p>	<p style="text-align: center; margin: 0;">CALCULATE FINAL OFFSET = $\frac{R - L}{2}$</p> <p>HORIZONTAL OFFSET: ACTUAL HORIZONTAL READING: A _____</p> <p>ACTUAL HORIZONTAL READING: B _____</p>	<p>D1 _____ D2 _____ D3 _____</p> 	
<p>PLUS</p> <p style="font-size: 2em;">+</p> <p>MINUS</p> <p style="font-size: 2em;">-</p>			<p>MINUS</p> <p style="font-size: 2em;">-</p> <p>PLUS</p> <p style="font-size: 2em;">+</p>	
<p>A</p>			<p>B</p>	
<p>MINUS</p> <p style="font-size: 2em;">-</p>			<p>PLUS</p> <p style="font-size: 2em;">+</p>	
<p>MINUS</p> <p style="font-size: 2em;">-</p>			<p>PLUS</p> <p style="font-size: 2em;">+</p>	
<p>FINAL SHIMS _____</p> <p>SOFT FOOT _____</p>			<p>FINAL SHIMS _____</p> <p>SOFT FOOT _____</p>	
			<p>FINAL SHIMS _____</p> <p>SOFT FOOT _____</p>	
<p>PERFORMED BY: _____</p>			<p>PERFORMED BY: _____</p>	
<p>WITNESSED BY: _____</p>			<p>WITNESSED BY: _____</p>	
<p>DATE: _____</p>			<p>DATE: _____</p>	